

Portable Bluetooth Wireless Speaker



USER MANUAL

SMPS-621



PLEASE READ THIS USER MANUAL COMPLETELY BEFORE OPERATING THIS UNIT AND RETAIN THIS BOOKLET FOR FUTURE REFERENCE.

COMPLIANCE WITH FCC REGULATIONS

This device complies with Part 15 of the FCC Rules. Operation is subject to the following two conditions:

- (1) this device may not cause harmful interference, and
- (2) this device must accept any interference received, including interference that may cause undesired operation.

NOTE : This equipment has been tested and found to comply with the limits for a Class B digital device, pursuant to Part 15 of the FCC Rules. These limits are designed to provide reasonable protection against harmful interference in a residential installation. This equipment generates, uses and can radiate radio frequency energy and, if not installed and used in accordance with the instructions, may cause harmful interference to radio communications. However, there is no guarantee that interference will not occur in a particular installation. If this equipment does cause harmful interference to radio or television reception, which can be determined by turning the equipment off and on, the user is encouraged to try to correct the interference by one or more of the following measures:

- Reorient or relocate the receiving antenna.
- Increase the separation between the equipment and receiver.
- Connect the equipment into an outlet on a circuit different from that to which the receiver is connected.
- Consult the dealer or an experienced radio/TV technician for help.

CAUTION: Changes or modifications not expressly approved by the party responsible for compliance could void the user's authority to operate the equipment.

Dear JENSEN Customer

Selecting fine audio equipment such as the unit you've just purchased is only the start of your musical enjoyment. Now it's time to consider how you can maximize the fun and excitement your equipment offers. This manufacturer and the Electronic Industries Association's Consumer Electronics Group want you to get the most out of your equipment by playing it at a safe level. One that lets the sound come through loud and clear without annoying blaring or distortion and, most importantly, without affecting your sensitive hearing. Sound can be deceiving. Over time your hearing "comfort level" adapts to higher volumes of sound. So what sounds "normal" can actually be loud and harmful to your hearing. Guard against this by setting your equipment at a safe level BEFORE your hearing adapts.

To establish a safe level:

- Start your volume control at a low setting.
- Slowly increase the sound until you can hear it comfortably and clearly, and without distortion.
- Once you have established a comfortable sound level. Set the dial and leave it there.

Take a minute to do this now will help to prevent hearing damage or loss in the future. After all, we want you listening for a lifetime.

We Want You Listening For a Lifetime

Used wisely, your new sound equipment will provide a lifetime of fun and enjoyment. Since hearing damage from loud noise is often undetectable until it is too late, this manufacturer and the Electronic Industries Association's Consumer Electronics Group recommend you avoid prolonged exposure to excessive noise.

Customer's Record:

The serial number of this product is found on its bottom. You should note the serial number of this unit in the space provided as a permanent record of your purchase to aid in identification in the event of theft or loss.



Model Number: SMPS-621

Serial Number: _____

PROTECT YOUR FURNITURE!!

This system is equipped with non-skid rubber 'feet' to prevent the product from moving when you operate the controls. These 'feet' are made from non-migrating rubber material specially formulated to avoid leaving any marks or stains on your furniture. However certain types of oil based furniture polishes, wood preservatives, or cleaning sprays may cause the rubber 'feet' to soften, and leave marks or a rubber residue on the furniture. To prevent any damage to your furniture we strongly recommend that you purchase small self-adhesive felt pads, available at hardware stores and home improvement centers everywhere, and apply these pads to the bottom of the rubber 'feet' before you place the product on fine wooden furniture.

PRODUCT FEATURES

The SMPS-621 is a Bluetooth portable stereo speaker with the following features:

- Wireless playback of music from your Bluetooth enabled device via the Bluetooth connection.
- With NFC (Near Field Communication) function.
- Hands-free Bluetooth Speakerphone.
- Up to 33 feet (10 meters) operating range.
- Auxiliary input jack to play music from your iPod or digital audio player.
- Digital volume control.

GETTING STARTED





ACCESSORIES INCLUDED

Carefully remove the unit and all the accessories from the gift box. Please verify that you have all the following accessories before recycling the gift box.

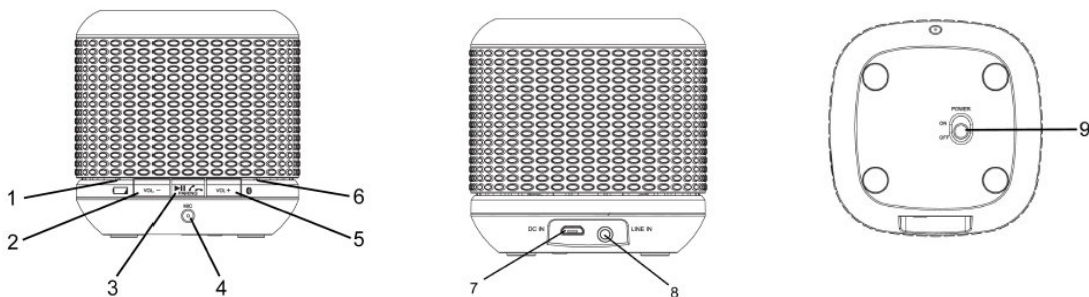
- User manual
- USB cable

LOCATION OF CONTROLS



1. BATTERY INDICATOR 
2. VOLUME - BUTTON
3. PLAY/PAUSE  / PAIRING / PHONE BUTTON 
4. MICROPHONE
5. VOLUME + BUTTON
6. BLUETOOTH STATUS INDICATOR 
7. CHARGING JACK (MICRO USB JACK)
8. LINE IN JACK
9. POWER ON/OFF SWITCH

CHARGING INSTRUCTIONS

The SMPS-621 operates on a built-in Li-ion battery that can be recharged using either the USB port on your computer or from a USB power adaptor (not included) with a rated output of DC 5V/500mA and up.

Note: The micro USB CHARGING JACK located on this unit is only designed for charging the built-in Li-ion battery.

CHARGING THE BATTERY FOR FIRST TIME

- 1.) Charge the built-in Li-ion battery a minimum of 2 hours prior to first use.
Plug the unit into the USB port on your computer or into a USB power adaptor (not included) using the included USB cable.
- 2.) The BATTERY INDICATOR (Red)  (#1) will turn "ON" while charging and turn "OFF" when the unit is fully charged. Unplug the USB cable from the power source once the battery is fully charged.

RECHARGING THE INTERNAL BATTERY

After prolonged use, the internal battery will become weak and the operation may become intermittent. When the internal battery charge is low, the BATTERY INDICATOR (Red)  (#1) will turn "ON and FLASH" alerting you to recharge the internal battery as soon as possible.

Plug the SMPS-621 into a USB port on your computer or into a USB power adaptor, DC 5V/500mA and up, (not included) using the included USB cable. Disconnect the USB cable from the speaker as soon as it is fully charged.

- Note:**
1. Charging time will vary if you are listening to music while charging the internal battery at the same time. We recommend you switch off the SMPS-621 power during the charging process.
 2. To prolong the life of a rechargeable battery, it is recommended to completely discharge it before fully charging it again.
 3. Rechargeable batteries need to be cycled for maximum performance and longer battery life. If you don't use the player that often, be sure to recharge the battery at least once a month in order to keep the internal battery working properly.

Battery Note and Care

- Do not burn or bury batteries.
- Do not puncture or crush.
- Do not disassemble.
- Do not dispose of batteries in fire, batteries may explode or leak
- Li-ion batteries must be recycled. Do not dispose of in the trash.
- Use only chargers rated for Li-ion cells. Be sure the charger's voltage and current settings are correct for the battery pack being charged.
- Charge batteries on a fireproof surface and away from flammable items or liquids.
- Batteries should NEVER be left unattended while charging. Only adults should charge the batteries.
- Follow the manufacturer's instructions for charging the product and do not charge longer than recommended. Unplug the charger when the battery is charged or not in use.





NOTE: The speaker is not magnetically shielded and may cause color distortion on the screen of some TVs or video monitors. To avoid this, you may need to move the unit further away from the TV or monitor if an unnatural color shifts or image distortion occurs.

PAIRING WITH YOUR BLUETOOTH DEVICE

ABOUT PAIRING

Pairing is the term used when two Bluetooth devices are connected wirelessly for the first time. This allows the devices to see each other and sets up a one to one communication channel between both devices.



To begin pairing with a Bluetooth device

1. Slide the POWER ON/OFF SWITCH (#9) to ON to turn on the unit. The BLUETOOTH STATUS INDICATOR  (#6) will light blue and flash and the melody "TRI-TONE" is heard. The unit is now ready to pair (link) with your Bluetooth device.
[Make sure an audio cable is not connected to LINE IN JACK (#8)]
2. Turn on Bluetooth function of your device and enable the search or scan function to find SMPS-621. (see your device's instructions to add or setup a Bluetooth device).
3. Select "SMPS621" from the device list when it appears on your device screen. If required, enter the pass code "0000" to pair (link) SMPS-621 with your device.
4. If you are pairing (linking) your computer to the speaker using Bluetooth, you may need to set the SMPS-621 as your computer's default sound device.
5. Once paired with a device, the BLUETOOTH STATUS INDICATOR  (#6) will light steadily and you will hear the sound "DOM" to confirm that pairing is completed.
6. If you want SMPS-621 change to pair with another Bluetooth Enable Device. Press and hold the  /  / PAIRING button (#3) for about 4~5 seconds. The BLUETOOTH STATUS INDICATOR  (#6) will flash, the melody "CALYPSO" will be heard to confirm the unit will go into Pairing/Discoverable mode again. Repeat steps 2 and 3.

To connect a previously paired Bluetooth device

The SMPS-621 can store one previously paired device for quick pairing during the power on cycle. When the unit is powered on and the previously paired device is found within the operating range, the unit will pair and connect with the device automatically.

NOTE:

- Due to different operating systems found in Bluetooth devices, the time to complete the pairing process might be different from unit to unit. If the pairing is not successful the first time, please try restarting the pairing process again by pressing and holding the  /  / PAIRING button (#3) until the BLUETOOTH STATUS INDICATOR  (#6) flashes.
- The pairing time might be longer the first time pairing or when pairing a new Bluetooth device.
- Make sure you have the latest firmware for your Bluetooth mobile devices.
- Make sure your device is working properly. Check your device's manual for details on Bluetooth pairing and linking.
- Refer to manual of your cell phones, tablet PC, computer or other Bluetooth enabled device for Bluetooth operation since it may vary from model to model.

PLAYING FROM A BLUETOOTH DEVICE

You can play music from your Bluetooth device wirelessly to SMPS-621 after successfully pairing.





1. Selecting your favorite song, press the PLAY button on your Bluetooth device or the /PAIRING button (#3) on SMPS-621 to play or pause the Bluetooth device playback.
2. Slowly adjust both the VOLUME +/- buttons (#2/#5) of your SMPS-621 and your Bluetooth device until you reach a comfortable listening level.

Notes:

1. Your Bluetooth enabled device will not play the music through the speaker, even if connected (linked), if the device does not support the A2DP Bluetooth profile.
2. Remember to turn off the SMPS-621 when you have finished listening, set the POWER ON/OFF SWITCH (#9) to the “OFF” position.
3. Don't forget to switch off the power of your external audio device as well

USING SMPS-621 AS A HANDS-FREE SPEAKERPHONE

To use your Bluetooth speaker as a speakerphone for receiving a phone call from a Bluetooth enabled phone.

1. Follow the “**PAIRING WITH YOUR BLUETOOTH DEVICE**” section to set up the Bluetooth connection with your smartphone.
2. When a call is received while music is playing, the music will be replaced by a ringtone. Press the /PAIRING button (#3) once to answer the call.
3. Use the VOLUME +/- buttons (#2/#5) to adjust the desired volume level.
4. To ignore an incoming call, simply press and hold the /PAIRING button (#3) for about 3 to 4 seconds, a beep sound will be heard and the call was ignored.
5. When the call is completed, press the /PAIRING button (#3) once to end the call. If you were playing music from the SMPS-621 before answering the call, the music will automatically resume playing when you hang up.
6. Tap the /PAIRING button (#3) twice to re-dial the last number you dialed.

CONNECTING WITH A SMARTPHONE BY ONE TOUCH (NFC)

ABOUT NFC

NFC (Near Field Communication) is a technology enabling short-range wireless communication between various devices, such as mobile phones and IC tags. Thanks to the NFC function, data communication can be achieved easily just by touching the relevant symbol or designated location on NFC compatible devices.

1. Make sure your Smartphone and the NFC function is turned on.
2. Hold the back of your smartphone against the “JENSEN” logo on the SMPS-621 until hear a confirmation tone is heard to confirm the pairing is completed.
3. Some smartphones may ask you to confirm the pairing if they were not paired before.

NOTE: If you have multiple NFC compatible devices, just touch the smartphone to a different device to switch the connection to that device. For example, when your smartphone is connected with NFC compatible headphones, just touch the smartphone to the system to change the Bluetooth connection to the system (one touch connection switching).

LINE IN OPERATION

You can play other music sources (iPod, MP3 or other digital audio players) through the speakers of this unit by connecting the LINE IN JACK (#8) to your external player's audio out jack or headphone jack.

1. Plug one end of an audio cable (not included) into the LINE IN JACK (#8) and the other end of the cable to the headphone jack of your digital audio player.
2. Set the POWER ON/OFF SWITCH (#9) to turn on the unit. The BLUETOOTH STATUS INDICATOR  (#6) will light Green steadily.
3. Start playing the device you plugged into the LINE IN JACK (#8).
4. Slowly adjust both the volume controls of your SMPS621 and the external device until you reach a comfortable listening level.
5. Turn off your iPod, MP3 player etc. when finish listening.
6. Set the POWER ON/OFF SWITCH (#9) to the “OFF” position to turn SMPS-621 off and unplug the AUX IN Jack.

NOTE:

- Play/Pause control  only works in Bluetooth mode and not in Line In mode.
- If you are connected to the Line Out Jack of your external device then you only need to adjust the volume control on the SMPS-621. If you're connected to the Headphone Jack of your external device, then you may need to adjust both the volume control of your external device and the SMPS-621 to obtain the most desirable volume setting.
- If you use Line In function when playing Bluetooth audio, Bluetooth audio will be temporarily disconnected when the audio cable is plugged in. Unplugging the audio cable will resume Bluetooth audio. We suggest you turn off the Bluetooth function of your Smartphone to save battery power when playing music via Line In mode.

CARE AND MAINTENANCE

1. Avoid operating your unit under direct sunlight or in hot, humid or dusty places.
2. Keep your unit away from heating appliances and sources of electrical noise such as fluorescent lamps or motors.

CLEANING THE UNIT

- To prevent fire or shock hazard, disconnect your unit from the USB port of power source when cleaning.
- The finish on the unit may be cleaned with a dust cloth and cared for as other furniture. Use caution when cleaning and wiping the plastic parts.
- If the cabinet becomes dusty wipe it with a soft dry dust cloth. Do not use any wax or polish sprays on the cabinet.
- If the cabinet becomes dirty or smudged with fingerprints it may be cleaned with a soft cloth slightly dampened with a mild soap and water solution. Never use abrasive cloths or polishes as these will damage the finish of your unit.

CAUTION : Never allow any water or other liquids to get inside the unit while cleaning.

TROUBLESHOOTING GUIDE

Symptom	Possible Problem	Solution
No Charging	The USB power adaptor (not included) is not plugged into a wall outlet or the USB cable (included) is not plugged into the mini USB jack on the SMPS-621.	Plug the USB power adaptor (not included) into a wall outlet and plug the USB cable (included) into the mini USB jack on the SMPS-621.
	Wall outlet is not functioning.	Plug another device into the same outlet to confirm the outlet is working.
	Computer USB port is not functioning.	Make sure your computer power is turned on and try another USB port.
No Sound	The SMPS-621 battery is exhausted.	Recharge the SMPS-621 battery.
	The SMPS-621 is not linked with the Bluetooth enabled device.	Go through "Pairing with your Bluetooth device" process to link the speaker.
	The SMPS-621 placement out of range.	Relocate the SMPS-621 within Bluetooth operating range (30 feet).
	Volume set too low.	Press the Volume + button to increase the sound level.
Sound is distorted.	Volume level is set too high.	Decrease the volume of the speaker.
	Sound source is distorted.	If the source sound file is of poor quality, distortion and noise are easily noticed with high-power speakers. Try a different audio source such as a music CD. If you are using an external sound source like older generation of iPod, try reducing the output volume on the device itself. Also try turning bass boost OFF or change the EQ setting.
Unit gets warm after extended play at high volume.	This is normal.	Turn the speaker off for a period of time or lower the volume.

SPECIFICATION

Power requirement:

DC input:	DC 5V  500mA (micro USB)
Battery	built-in rechargeable Lithium-ion battery
Bluetooth	Bluetooth Specification version 3.0 Support profile A2DP / HFP
Audio power output	2.5W (rms).
Dimensions	83mm (H) x 82.5cm(W) x 82.5cm(D)
Weight	292g

SPECTRA GREEN NOTICE



At Spectra, environmental and social responsibility is a core value of our business. We are dedicated to continuous implementation of responsible initiatives with an aim to conserve and maintain the environment through responsible recycling.

Please visit us at <http://www.spectraintl.com/green.htm> for more information on Spectra's green initiatives or to find a recycler in your area.

Bluetooth® is a registered trademark of Bluetooth SIG, Inc.

90 DAY LIMITED WARRANTY AND SERVICE VALID IN THE U.S.A. ONLY

SPECTRA MERCHANDISING INTERNATIONAL, INC. warrants this unit to be free from defective materials or factory workmanship for a period of 90 days from the date of original customer purchase and provided the product is utilized within the U.S.A. This warranty is not assignable or transferable. Our obligation under this warranty is the repair or replacement of the defective unit or any part thereof, except batteries, when it is returned to the SPECTRA Service Department, accompanied by proof of the date of original consumer purchase, such as a duplicate copy of a sales receipt.

You must pay all shipping charges required to ship the product to SPECTRA for warranty service. If the product is repaired or replaced under warranty, the return charges will be at SPECTRA's expense. There are no other express warranties other than those stated herein.

This warranty is valid only in accordance with the conditions set forth below:

1. The warranty applies to the SPECTRA product only while:
 - a. It remains in the possession of the original purchaser and proof of purchase is demonstrated.
 - b. It has not been subjected to accident, misuse, abuse, improper service, usage outside the descriptions and warnings covered within the user manual or non-SPECTRA approved modifications.
 - c. Claims are made within the warranty period.
2. This warranty does not cover damage or equipment failure caused by electrical wiring not in compliance with electrical codes or SPECTRA user manual specifications, or failure to provide reasonable care and necessary maintenance as outlined in the user manual.
3. Warranty of all SPECTRA products applies to residential use only and is void when products are used in a nonresidential environment or installed outside the United States.

This warranty gives you specific legal rights, and you may also have other rights which vary from state to state. TO OBTAIN SERVICE please remove all batteries (if any) and pack the unit carefully and send it freight prepaid to SPECTRA at the address shown below. IF THE UNIT IS RETURNED WITHIN THE WARRANTY PERIOD shown above, please include a proof of purchase (dated cash register receipt) so that we may establish your eligibility for warranty service and repair of the unit without cost. Also include a note with a description explaining how the unit is defective. A customer service representative may need to contact you regarding the status of your repair, so please include your name, address, phone number and email address to expedite the process.

IF THE UNIT IS OUTSIDE THE WARRANTY PERIOD, please include a check for \$20.00 to cover the cost of repair, handling and return postage. All out of warranty returns must be sent prepaid.

It is recommended that you contact SPECTRA first at 1-800-777-5331 or by email at custserv@spectraintl.com for updated information on the unit requiring service. In some cases the model you have may be discontinued, and SPECTRA reserves the right to offer alternative options for repair or replacement.

SPECTRA MERCHANDISING INTERNATIONAL, INC.
4230 North Normandy Avenue,
Chicago, IL60634, USA.
1-800-777-5331

To register your product, visit the link on the website below to enter your information.
<http://www.spectraintl.com/wform.htm>

0214

Printed in China