

---

Bluetooth Wireless Shower Speaker



**USER MANUAL**  
**SMPS-640**



PLEASE READ THIS USER MANUAL COMPLETELY BEFORE OPERATING THIS  
SPEAKER AND RETAIN THIS BOOKLET FOR FUTURE REFERENCE.

## DEAR JENSEN® CUSTOMER

Selecting fine audio equipment such as the unit you've just purchased is only the start of your musical enjoyment. Now it's time to consider how you can maximize the fun and excitement your equipment offers. This manufacturer and the Electronic Industries Association's Consumer Electronics Group want you to get the most out of your equipment by playing it at a safe level. One that lets the sound come through loud and clear without annoying blaring or distortion and, most importantly, without affecting your sensitive hearing. Sound can be deceiving. Over time your hearing "comfort level" adapts to higher volumes of sound. So what sounds "normal" can actually be loud and harmful to your hearing. Guard against this by setting your equipment at a safe level BEFORE your hearing adapts.

### To establish a safe level:

- Start your volume control at a low setting.
- Slowly increase the sound until you can hear it comfortably and clearly, and without distortion.

### Once you have established a comfortable sound level:

- Set the dial and leave it there.

Taking a minute to do this now will help to prevent hearing damage or loss in the future. After all, we want you listening for a lifetime.

### We Want You Listening For a Lifetime

Used wisely, your new sound equipment will provide a lifetime of fun and enjoyment. Since hearing damage from loud noise is often undetectable until it is too late, this manufacturer and the Electronic Industries Association's Consumer Electronics Group recommend you avoid prolonged exposure to excessive noise.



### Customer's Record:

The serial number of this product is found on its back cover. You should note the serial number of this unit in the space provided as a permanent record of your purchase to aid in identification in the event of theft or loss.

**Model Number: SMPS-640**

**Serial Number:** \_\_\_\_\_

## COMPLIANCE WITH FCC REGULATIONS

This device complies with Part 15 of the FCC Rules. Operation is subject to the following two conditions:

- (1) this device may not cause harmful interference, and
- (2) this device must accept any interference received, including interference that may cause undesired operation.

NOTE : This equipment has been tested and found to comply with the limits for a Class B digital device, pursuant to Part 15 of the FCC Rules. These limits are designed to provide reasonable protection against harmful interference in a residential installation. This equipment generates, uses and can radiate radio frequency energy and, if not installed and used in accordance with the instructions, may cause harmful interference to radio communications. However, there is no guarantee that interference will not occur in a particular installation. If this equipment does cause harmful interference to radio or television reception, which can be determined by turning the equipment off and on, the user is encouraged to try to correct the interference by one or more of the following measures:

- Reorient or relocate the receiving antenna.
- Increase the separation between the equipment and receiver.
- Connect the equipment into an outlet on a circuit different from that to which the receiver is connected.

- Consult the dealer or an experienced radio/TV technician for help.

**CAUTION: Changes or modifications not expressly approved by the party responsible for compliance could void the user's authority to operate the equipment.**

## PROTECT YOUR FURNITURE

This model is equipped with non-skid rubber 'feet' to prevent the product from moving when you operate the controls. These 'feet' are made from non-migrating rubber material specially formulated to avoid leaving any marks or stains on your furniture. However certain types of oil based furniture polishes, wood preservatives, or cleaning sprays may cause the rubber 'feet' to soften, and leave marks or a rubber residue on the furniture. To prevent any damage to your furniture we strongly recommend that you purchase small self-adhesive felt pads, available at hardware stores and home improvement centers everywhere, and apply these pads to the bottom of the rubber 'feet' before you place the product on fine wooden furniture.

## PRODUCT FEATURES

The SMPS-640 is a Bluetooth portable speaker with the following features:

- Wireless playback of music from your Bluetooth enabled device via the Bluetooth connection.
- Hands-free Bluetooth Speakerphone
- Up to 33 feet (10 meters) operating range.
- Digital volume control.

## GETTING STARTED

### ACCESSORIES INCLUDED



Carefully remove the unit and all the accessories from the gift box. Please verify that you have all the following accessories before recycling the gift box.

- User manual
- USB cable
- S hook

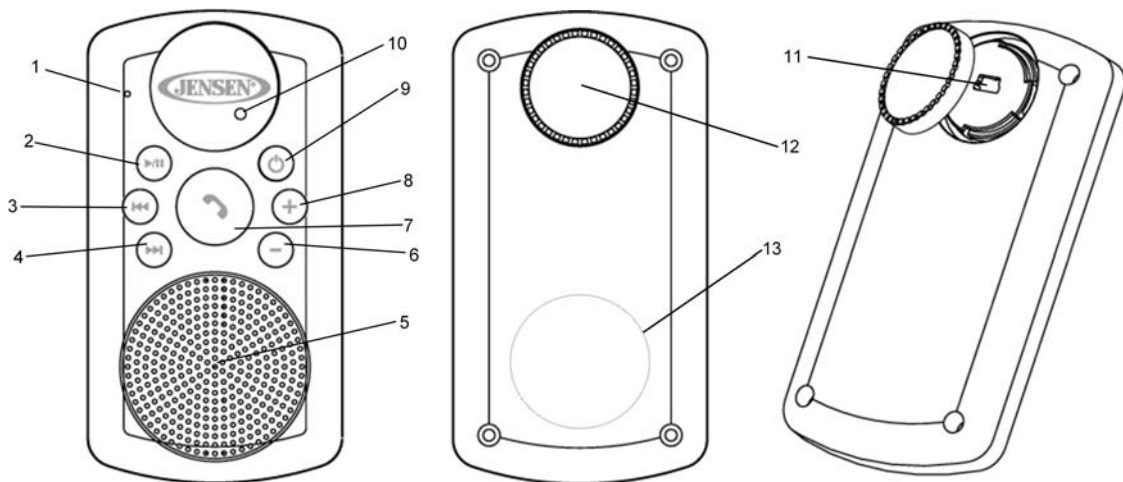
## LOCATION OF CONTROLS



1. Microphone
2. Play/Pause ►|| Button
3. Skip Backward ◀◀ Button
4. Skip Forward ►►| Button

5. **Speaker**
6. **Volume Down (-) Button**
7. **Phone  Button**
8. **Volume Up (+) Button**
9. **Power  Button**
10. **Power/Bluetooth Status indicator**
11. **Charging Jack (mini USB Jack)**
12. **Charging Jack Cover**
13. **NFC (Near Field Communication) Pairing Area**
14. **Hanging Strap**

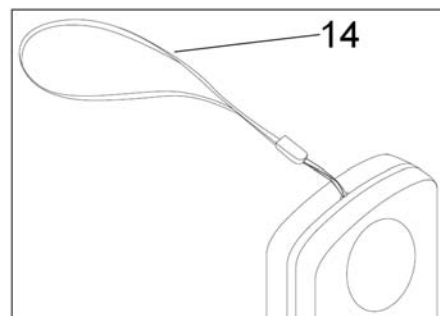

## CHARGING INSTRUCTIONS

This unit operates on a built-in rechargeable Li-ion battery that can be recharged either using the USB port on your computer or from a USB power adaptor (not included) with a rated output of DC 5V and a minimum 500mA.

**Note:** The **Charging Jack** located on this unit is only designed for charging the Li-ion battery.

### CHARGING THE BATTERY FOR FIRST TIME

- 1.) Charge the Li-ion battery a minimum of 3 hours prior to first use.  
Remove the **Charging Jack Cover** on the back of speaker by rotating it ¼ turn counter clockwise. Plug the one end of USB cable (included) into a USB port on your computer or into a USB power adaptor (not included), plug another end of cable to **Charging Jack** on the back of the SMPS-640.
- 2.) The **Power indicator** will be red while charging in the power OFF mode. When the red light turns off, the unit is fully charged. Unplug the USB cable from the power source once the battery is fully charged and replace the **Charging Jack Cover** on the back of speaker. Make sure the cover is secure to prevent moisture from getting into the unit.

### RECHARGING THE BATTERY

After prolonged use, the battery will become weak and operation may become intermittent. When the internal battery charge is very low, the **Power indicator** will flash red alerting you to recharge the internal battery as soon as possible. Plug the speaker into a USB port on your computer or into a DC 5V, 500mA, USB power adaptor (not included) using the included USB cable. Disconnect the USB cable from the speaker as soon as it is fully charged.

#### Charging in Power ON mode

- The **Power Indicator** LED is flashing blue & red light steadily while charging.
- The red light will be off & blue light will flashing slowly, when the battery is fully charged.

#### **Note:**

1. Charging time will vary if you are listening to music while charging the speaker battery. We recommend you turn off the speaker power during the charging process.
2. To prolong the life of a rechargeable battery, it is recommended to completely discharge it before fully charging it again.
3. A rechargeable battery need to be cycled for maximum performance and longer battery life. If you don't use the player that often, be sure to recharge the battery at least once a month in order to keep the internal

battery working properly.

#### Charging in Unit Power OFF mode

- The **Power Indicator** is RED while charging.
- The **Power Indicator** will change from red to blue when the battery is fully charged.



#### **Battery Note and Care**

- Do not burn or bury batteries.
- Do not puncture or crush.
- Do not disassemble.
- Recycle Li-ion batteries. Do not dispose of in the trash.
- If the electrolyte in the cells should get on your skin, thoroughly wash with soap and water. If in the eyes, rinse thoroughly with cool water. Immediately seek medical attention.
- Use only chargers rated for Li-ion cells. Be sure the charger's voltage and current settings are correct for the battery pack being charged.
- Charge batteries on the fireproof surface away from flammable items or liquids.
- Batteries should NEVER be left unattended while charging. Only adults should charge the batteries.
- Follow the manufacturer's instructions for charging the product and do not charge longer than recommended. Unplug the charger when the battery is charged or not in use.







#### Recycle Rechargeable Batteries

Recycle your old rechargeable batteries at one of the many collection sites in the U.S. and Canada. To find the site nearest you, visit [www.call2recycle.org](http://www.call2recycle.org) or call toll-free 1-877-2-RECYCLE

**NOTE:** The speaker is not magnetically shielded and may cause color distortion on the screen of some TVs or video monitors. To avoid this, you may need to move the unit further away from the TV or monitor if an unnatural color shifts or image distortion occurs.

### **TURNING THE SMPS-640 POWER ON/OFF**

- 1.) In power OFF mode, Press and hold the **Power**  **Button** about 3 seconds to turn the unit ON. Two melodies will be heard and the blue light around the **Phone**  **Button** will light indicating that the unit is ON.
- 2.) In power ON mode, press and hold the **Power**  **Button** about 2 seconds. A melody is heard and the blue light around the **Phone**  **Button** will turn OFF indicating that the power is now OFF.

### **OPERATING THE UNIT**

1. If the unit has never been paired with a Bluetooth device before. You need to follow the pairing instructions below to link the unit with your Bluetooth device.
  - Press the **Power**  **Button** to turn on the unit.
  - The **Bluetooth Status Indicator** will be flashing rapidly and 2 melodies will heard, the unit will goes into Pairing/Discoverable mode.
  - Turn on the Bluetooth function of your Bluetooth device and enable the search or scan function to find the unit.

- Select "SMPS-640" from the device list when it appears on your device screen. If required, enter the pass code "0000" to pair (link) the unit with your device.
  - After successfully pairing (linking) the Bluetooth enabled device the **Bluetooth Status Indicator** will be flashing slowly and a short beep will heard.
2. Turn on the unit, 2 melodies will heard. The unit is searching the last paired device. Once it is found, the **Bluetooth Status Indicator** will be flashing slowly.
  3. After successfully pairing (linking), you can begin playing music from your Bluetooth enabled device wirelessly to the speaker.
  4. Press the **Volume +/ Volume - Button** on the speaker to adjust to the desired volume level.
  5. After selecting your favorite song, press **Play / Pause ►|| Button** on the unit to play or pause the playback song.
  6. Press **◀◀** or **▶▶** button to skip to the previous or next song.
  7. Press and hold the **◀◀** or **▶▶** button for fast reverse or fast forward during playback.
  8. If the unit need to pair with another Bluetooth device. Press and hold the **Play / Pause ►|| Button** for 4~5 seconds. The **Bluetooth Status Indicator** will be flashing rapidly and 2 short beeps will heard, the unit will goes into Pairing/Discoverable mode again. Repeat last 2 steps on point 1 above.

#### **Notes:**

1. Refer to manual of your cell phone, tablet PC, computer or other Bluetooth enabled devices for Bluetooth operation since it may vary from model to model.
2. If your Bluetooth enabled device does not support A2DP profile, it will not play the music through the speaker, even if paired (linked).
3. If you are pairing (linking) your computer to the unit using Bluetooth, you may need to set the speaker as your computer's default sound device.
4. If the SMPS-640 is left idle for about 3 minutes without linking to any Bluetooth enabled device, it will automatically turn off to save battery power.
5. **The Bluetooth enabled device and the SMPS-640 should be operated in the same room for best operation.**

#### **Using the SMPS-640 as a Hands-free Bluetooth Speakerphone**

1. Link your cell phone to the SMPS-640 via Bluetooth as described above.
2. When receiving an incoming call on your cell phone, tap the **Phone ↻ Button** on the speaker to switch the incoming call from cell phone to the SMPS-640. Two short beep sounds will be heard confirming the call is being answered. Complete your call using the built-in microphone and speaker on the SMPS-640.
3. Adjust the volume control on the speaker obtain the desired sound level.
4. To end the call, just tap the **Phone ↻ Button** again on the SMPS-640. A short beep sound will be heard and the call will end. If you were playing music from your cell phone to the SMPS-640 before answering the call, the music will automatically resume playing when you hang up.
5. To ignore an incoming call, simply press **Phone ↻ Button** twice on the speaker, two short beeps will be heard and the call will be ignored.

#### **Hang up with the SMPS-640**

A quick press on the **Phone ↻ Button** will end the call in progress. A short beep tone will be heard from the speaker confirming the call has ended.

#### **Redialing the last number with the speaker**

Tapping the speaker **Phone ↻ Button** twice and a short beep will be heard. The

speaker will automatically redial the last number.

**Note:** This feature is phone dependent and may not operate on all cell phones.

### **Re-linking to the cell phone**

If your cell phone is already paired (linked) with the SMPS-640, but became unlinked even with both Bluetooth devices turned on. You can re-link them by:

1. Turning off the SMPS-640 and then turning it on again to re-link your cell phone.
2. You can also re-link the speaker by using Bluetooth operation of your cell phone. Please refer to operation manual of your cell phone for more information.

## **LINKING WITH THE NFC**

The SMPS-640 features Near Field Communication (NFC), so you can easily pair and connect the speaker with your compatible Bluetooth device much easier.

If the compatible Bluetooth device you want to link supports NFC, activate the NFC feature on the device, and touch the **NFC Pairing Area** of the speaker with the NFC area on your device. The speaker connects to the device automatically. For details on NFC, see the user guide that came with the Bluetooth device that you are trying to connect.

**Note:** This feature is compatible with Android 4.0 and up. Android 4.0 users will need to install an App called “tap-and-pair” that is available on Google play.

This feature is phone dependent and may not operate on all cell phones or devices.

## **CARE AND MAINTENANCE**

1. Avoid operating your unit under direct sunlight or in hot, humid or dusty places.
2. Keep your unit away from heating appliances and sources of electrical noise such as fluorescent lamps or motors.
3. Before using, make sure the **Charging Jack Cover** is on and tightly secured.

### **CLEANING THE UNIT**

- To prevent fire or shock hazard, disconnect your unit from the USB port of power source when cleaning.
- The finish on the unit may be cleaned with a dust cloth and cared for as other furniture. Use caution when cleaning and wiping the plastic parts.
- If the cabinet becomes dusty wipe it with a soft dry dust cloth. Do not use any wax or polish sprays on the cabinet.
- If the cabinet becomes dirty or smudged with fingerprints it may be cleaned with a soft cloth slightly dampened with a mild soap and water solution. Never use abrasive cloths or polishes as these will damage the finish of your unit.

**CAUTION: Never allow any water or other liquids to get inside the unit while cleaning.**

## **TROUBLESHOOTING GUIDE**

<b>Symptom</b>	<b>Possible Problem</b>	<b>Solution</b>
No Charging	The USB power adaptor (not included) is not plugged into a wall outlet or the USB cable (included) is not plugged into the mini USB jack on the SMPS-640.	Plug the USB power adaptor (not included) into a wall outlet and plug the USB cable (included) into the mini USB jack on the SMPS-640.
	Wall outlet is not functioning.	Plug another device into the same outlet to confirm the outlet is working.

	Computer USB port is not functioning.	Make sure your computer power is turned on and try another USB port.
No Sound	The SMPS-640 battery is dead.	Recharge the SMPS-640 battery.
	The SMPS-640 is not linked with the Bluetooth enabled device.	Go through "Operating the Unit" process to link the speaker.
	The SMPS-640 placement out of range.	Relocate the SMPS-640 within Bluetooth operating range (30 feet).
	Volume set too low.	Press the <b>Volume + button</b> to turn the sound level up.
Sound is distorted.	Volume level is set too high.	Decrease the volume of the speaker.
	Sound source is distorted.	If the source sound file is of poor quality, try playing a higher quality music file. Try turning bass boost OFF or change the EQ setting. This can contribute to distortion on some speakers.
Unit gets warm after extended play at high volume.	This is normal.	Turn the speaker off for a period of time or lower the volume.

## SPECIFICATIONS

### Power Requirement

Main unit

DC 3.7V 800mAh rechargeable Li-ion Battery



At Spectra, environmental and social responsibility is a core value of our business. We are dedicated to continuous implementation of responsible initiatives with an aim to conserve and maintain the environment through responsible recycling.

Please visit us at <http://www.spectraintl.com/green.htm> for more information on Spectra's green initiatives or to find a recycler in your area.

Bluetooth® is a registered trademark of Bluetooth SIG, Inc.

## 90 DAY LIMITED WARRANTY AND SERVICE

### VALID IN THE U.S.A. ONLY

SPECTRA MERCHANDISING INTERNATIONAL, INC. warrants this unit to be free from defective materials or factory workmanship for a period of 90 days from the date of original customer purchase and provided the product is utilized within the U.S.A. This warranty is not assignable or transferable. Our obligation under this warranty is the repair or replacement of the defective unit or any part thereof, except batteries, when it is returned to the SPECTRA Service Department, accompanied by proof of the date of original consumer purchase, such as a duplicate copy of a sales receipt.

You must pay all shipping charges required to ship the product to SPECTRA for warranty service. If the product is repaired or replaced under warranty, the return charges will be at SPECTRA's expense. There are no other express warranties other than those stated herein.

This warranty is valid only in accordance with the conditions set forth below:

1. The warranty applies to the SPECTRA product only while:
  - a. It remains in the possession of the original purchaser and proof of purchase is demonstrated.
  - b. It has not been subjected to accident, misuse, abuse, improper service, usage outside the



descriptions and warnings covered within the user manual or non-SPECTRA approved modifications.

- c. Claims are made within the warranty period.
2. This warranty does not cover damage or equipment failure caused by electrical wiring not in compliance with electrical codes or SPECTRA user manual specifications, or failure to provide reasonable care and necessary maintenance as outlined in the user manual.
3. Warranty of all SPECTRA products applies to residential use only and is void when products are used in a nonresidential environment or installed outside the United States.

This warranty gives you specific legal rights, and you may also have other rights which vary from state to state. TO OBTAIN SERVICE please remove all batteries (if any) and pack the unit carefully and send it freight prepaid to SPECTRA at the address shown below. IF THE UNIT IS RETURNED WITHIN THE WARRANTY PERIOD shown above, please include a proof of purchase (dated cash register receipt) so that we may establish your eligibility for warranty service and repair of the unit without cost. Also include a note with a description explaining how the unit is defective. A customer service representative may need to contact you regarding the status of your repair, so please include your name, address, phone number and email address to expedite the process.

IF THE UNIT IS OUTSIDE THE WARRANTY PERIOD, please include a check for \$30.00 to cover the cost of repair, handling and return postage. All out of warranty returns must be sent prepaid.

It is recommended that you contact SPECTRA first at 1-800-777-5331 or by email at [custserv@spectraintl.com](mailto:custserv@spectraintl.com) for updated information on the unit requiring service. In some cases the model you have may be discontinued, and SPECTRA reserves the right to offer alternative options for repair or replacement.

SPECTRA MERCHANDISING INTERNATIONAL, INC.  
4230 North Normandy Avenue,  
Chicago, IL60634, USA.  
1-800-777-5331

To register your product, visit the link on the website below to enter your information.  
<http://www.spectraintl.com/wform.htm>

0113

Printed in China