



PERSONAL CASSETTE PLAYER/RECORDER WITH AM/FM RADIO



USER MANUAL MCR-75

PLEASE READ THIS USER MANUAL COMPLETELY BEFORE OPERATING THIS UNIT AND RETAIN THIS BOOKLET FOR FUTURE REFERENCE.

IMPORTANT SAFETY INFORMATION

- Read these instructions.
- Keep these instructions.
- Heed all warnings.
- Follow all instructions.
- Do not use these apparatus near water.
- Clean only with dry cloth.
- Do not block any ventilation openings.
- Install in accordance with manufacturer's instructions.
- Do not install or operate near any heat sources such as radiators, stoves, or other apparatus that produce heat.
- No naked flame sources such as candles should be placed on the product.
- Battery shall not be exposed to excessive heat such as sunshine, fire or the like.
- Danger of explosion if battery is incorrectly replaced. Replace only with the same or equivalent type.
- Attention should be drawn to the environmental aspects of battery disposal.

COMPLIANCE WITH FCC REGULATIONS

This device complies with Part 15 of the FCC Rules. Operation is subject to the following two conditions:

- (1) this device may not cause harmful interference, and
- (2) this device must accept any interference received, including interference that may cause undesired operation.

NOTE: This equipment has been tested and found to comply with the limits for a Class B digital device, pursuant to Part 15 of the FCC Rules. These limits are designed to provide reasonable protection against harmful interference in a residential installation. This equipment generates uses and can radiate radio frequency energy and, if not installed and used in accordance with the instructions, may cause harmful interference to radio communications. However, there is no guarantee that interference will not occur in a particular installation. If this equipment does cause harmful interference to radio or television reception, which can be determined by turning the equipment off and on, the user is encouraged to try to correct the interference by one or more of the following measures:

- Reorient or relocate the receiving antenna.
- Increase the separation between the equipment and receiver.
- Connect the equipment into an outlet on a circuit different from that to which the receiver is connected.
- Consult the dealer or an experienced radio/TV technician for help.

CAUTION: Changes or modifications not expressly approved by the party responsible for compliance could void the user's authority to operate the equipment.

E-1

DEAR JENSEN® CUSTOMER

Selecting fine audio equipment such as the unit you've just purchased is only the start of your musical enjoyment. Now it's time to consider how you can maximize the fun and excitement your equipment offers. This manufacturer and the Electronic Industries Association's Consumer Electronics Group want you to get the most out of your equipment by playing it at a safe level. One that lets the sound come through loud and clear without annoying blaring or distortion and, most importantly, without affecting your sensitive hearing. Sound can be deceiving. Over time your hearing "comfort level" adapts to higher volumes of sound. So what sounds "normal" can actually be loud and harmful to your hearing. Guard against this by setting your equipment at a safe level BEFORE your hearing adapts.

To establish a safe level:

- Start your volume control at a low setting.
- Slowly increase the sound until you can hear it comfortably and clearly, and without distortion.
- Once you have established a comfortable sound level. Set the dial and leave it there.

Take a minute to do this now will help to prevent hearing damage or loss in the future. After all, we want you listening for a lifetime.

We Want You Listening For a Lifetime

Used wisely, your new sound equipment will provide a lifetime of fun and enjoyment. Since hearing damage from loud noise is often undetectable until it is too late, this manufacturer and the Electronic Industries Association's Consumer Electronics Group recommend you avoid prolonged exposure to excessive noise.



Customer's Record:

The serial number of this product is found inside the battery compartment. You should note the serial number of this unit in the space provided as a permanent record of your purchase to aid in identification in the event of theft of loss.

Model Number: MCR-75

Serial Number: _____

E-2

LOCATION OF CONTROLS

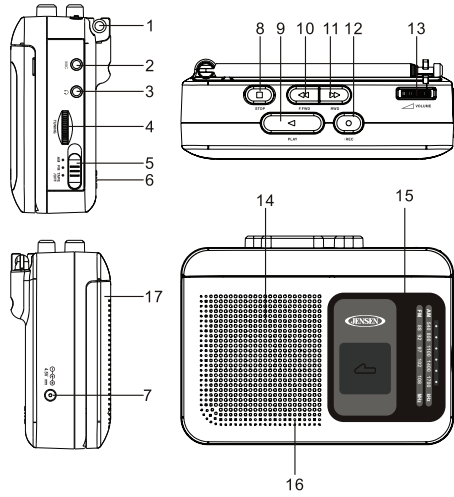

1	FM TELESCOPIC ANTENNA	10	FAST FORWARD BUTTON
2	EXTERNAL MIC JACK	11	REWIND BUTTON
3	HEADPHONE JACK	12	RECORD BUTTON
4	TUNING KNOB	13	VOLUME CONTROL
5	FUNCTION SWITCH	14	SPEAKER
6	BATTERY DOOR	15	AM/FM DIAL SCALE
7	DC JACK	16	BUILT-IN MICROPHONE
8	STOP BUTTON	17	CASSETTE DOOR
9	PLAY BUTTON		

E-3

POWER SOURCE

This cassette player operates on two 1.5V DC "AA" size (UM-3) alkaline batteries (Not Included) or with an AC-DC adaptor with 4.5V DC 350mA output (Not Included).

BATTERY OPERATION (BATTERIES NOT INCLUDED)

- Open the battery door located on the back of the unit.
- Follow the polarity diagram (+ and -) shown on the back of the cabinet, and insert 2 "AA" (UM-3) batteries (not included), and close the battery door.

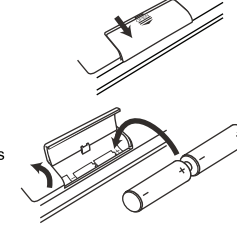

IMPORTANT: Be sure that the batteries are installed correctly. Wrong polarity could damage the unit and void the warranty.

- Notes:**
- If you are using an AC Adaptor (not included), please unplug it from the unit before installing the batteries.
 - For best performance and longer operating time, we recommend the use of good quality alkaline battery.
 - The batteries need to be replaced when if the volume level becomes significantly lower, if the sound is distorted during operation or the unit no longer functions properly.

BATTERY WARNING

- Be sure the batteries are installed correctly. Wrong polarity may damage the unit.
- Use only the size and type of batteries specified.
- Do not mix old and new batteries.
- Do not mix alkaline, standard (carbon-zinc) or rechargeable (nickel-cadmium) batteries.
- If the unit is not to be used for an extended period of time, remove the batteries. Old or leaking batteries can cause damage to the unit and may void the warranty.
- Do not try to recharge batteries not intended to be recharged; they can overheat and rupture. (Follow battery manufacturer's directions).
- Do not dispose of batteries in fire, batteries may leak or explode.

E-4

AC ADAPTOR OPERATION (AC ADAPTOR NOT INCLUDED)

- Plug the cord of the AC adaptor into the DC IN JACK (#7) of the unit.
- Plug the AC adaptor into a household 120V/60Hz AC power outlet.
- The batteries will automatically disconnect when the AC adaptor is plugged into the unit and the unit will operate using the AC adaptor power.

NOTE: Only use adaptor with an output voltage rated at DC 4.5V±350mA with a center positive plug.

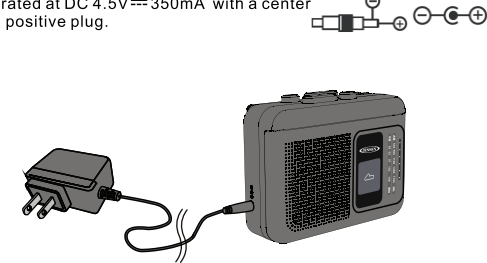

RADIO OPERATION

- Set the FUNCTION SWITCH (#5) to AM or FM position.
- Turn the TUNING KNOB (#4) to select the desired radio station.
- Adjust the VOLUME CONTROL (#13) to obtain the desired sound level.
- To turn the radio off, switch the FUNCTION SWITCH to "TAPE" position.

TIPS FOR BEST RADIO RECEPTION

- The Telescopic Antenna should be fully extended to get the best FM reception.
- When using the AM radio, be sure to place the unit in a vertical position. For best AM reception, keep turning the unit slowly while keeping it vertical until the best signal is obtained.

E-5

CASSETTE PLAYER OPERATION

CASSETTE PLAYBACK

- Open the CASSETTE DOOR (#17) and insert a pre-recorded cassette tape with the exposed tape facing upwards then close the CASSETTE DOOR.

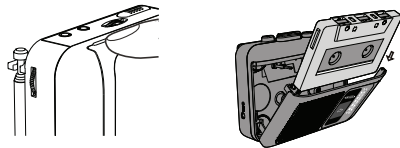

- Set the FUNCTION SWITCH (#5) to "TAPE" position.



- Press the PLAY BUTTON (#9) for tape playback.
- Adjust the VOLUME CONTROL (#13) to obtain the desired sound level.
- Press the FAST FORWARD BUTTON (#10) or REWIND BUTTON (#11) to quickly advance or rewind the tape.
- Press the STOP BUTTON (#8) at any time to stop playback. The tape playback will stop automatically when the end of the tape is reached.

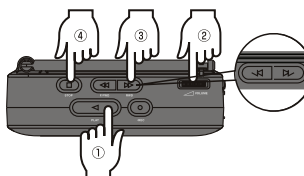

E-6

AUTOMATIC STOP

This unit is equipped with an Automatic Stop System to protect your cassette tapes and prevent unnecessary wear to the pinch roller of the cassette mechanism. When the tape ends during playback, the PLAY BUTTON (#9) will automatically release to stop the cassette from running.

CASSETTE RECORDING

Recording from the built-in microphone

- Open the CASSETTE DOOR (#17) and insert a blank cassette tape.
- Press the RECORD BUTTON (#12) and PLAY BUTTON (#9) down at the same time and the unit will start recording from the built-in microphone.
- Press the STOP BUTTON (#8) to stop recording.
- To listen to what was recorded, press the REWIND BUTTON (#11) to rewind the tape and then press the PLAY BUTTON (#9) to hear what was recorded.

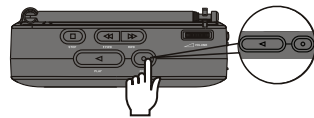

Recording from an external microphone (not included)

- Plug an external microphone (not included) into the external microphone jack (#2).
- Open the CASSETTE DOOR (#17) and insert a blank cassette tape.
- Press the RECORD BUTTON (#12) and PLAY BUTTON (#9) down at the same time and the unit will start recording from the external microphone.
- Press the STOP BUTTON (#8) to stop recording.
- To listen to what was recorded, press the REWIND BUTTON (#11) to rewind the tape and then press the PLAY BUTTON (#9) to hear what was recorded.



E-7

Recording from the radio

- Set the FUNCTION SWITCH (#5) to AM or FM and tune in the station you want to record using the tuning knob (#4).
- Press the RECORD BUTTON (#12) and PLAY BUTTON (#9) down at the same time and the unit will start recording from the radio.

NOTES:

- The unit features Auto Level Control (ALC), so the volume control (#13) does not affect the sound level when recording. When recording from either the built-in microphone or when using an external microphone, keep the microphone approximately 2 - 3 inches from the source that you are recording.
- You may receive some interference when recording from the AM radio.
- PROTECTION AGAINST ACCIDENTAL ERASURE:** When you record on a cassette, the previous recordings are erased automatically. To protect them against any risk of accidental erasure, cassettes are provided with protective tabs for this purpose. Remove the protective tab (or both) located at the top of the cassette using a knife or a screwdriver. If you subsequently need to re-record on a cassette protected in this way, you can cancel this protection by covering the hole revealed with a piece of adhesive tape. It is not possible to press the RECORD button if the protective tab has been removed and has not been replaced by adhesive tape.

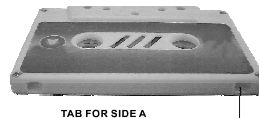

- Do not force down RECORD BUTTON (#12) if the tape's erase-protection tabs have been removed, or you will damage the recorder.

E-8

USING EARBUDS (NOT INCLUDED)

Plug a pair of earbuds (not included) into the HEADPHONE JACK (#3) to listen to the radio or a tape in private. The built-in speaker automatically disconnects when the earbuds are plugged in.

CAUTION

- AVOID EXCESSIVE VOLUME LEVELS FOR LONG PERIODS OF TIME LEVELS WHEN USING THE HEADPHONES. PROLONGED USE AT HIGH MAY IMPAIR YOUR HEARING.
- Do not use earbuds while operating a motorized vehicle, as it may create a traffic hazard and is illegal in many areas.

CARE AND MAINTENANCE

- Do not subject the unit to excessive force, shock, dust or extreme temperature.
- Do not tamper the internal components of the unit.
- Clean your unit with a dry cloth. Solvent or detergent should never be used.
- Avoid leaving your unit in direct sunlight or in hot, humid or dusty places.
- Keep your unit away from heating appliances and sources of electrical noise such as fluorescent lamps or motors.

CAUTION: Never allow any water or other liquids to get inside the unit while cleaning.

CASSETTE TAPE OPERATING TIPS

- High quality tapes are recommended to obtain maximum quality reproduction from recordings.
- Tapes with playing time of 120 minutes (C-120) are not recommended because they contain thinner and longer tape that has a greater chance to malfunction and jam, which may damage the cassette mechanism.
- To obtain good reproduction, the head should be cleaned after every 10 to 20 hours of use. It is also recommended that the cassette be kept away from excessive heat or cold.

E-9

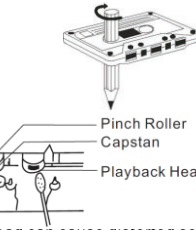

- If there is slack in the tape, remove the slack prior to inserting the cassette. To remove the slack, insert a pencil into the hub and rotate clockwise.
- A leader tape is provided at the beginning on each cassette. There is no recording on this area, so it is necessary to let the tape run for about five seconds to clear the head.
- Keep the tape head clean since a dirty head can cause distortion or improper tape speed. Depress the PLAY BUTTON (#9) and use a small cotton swab with tape head cleaner or alcohol to clean the tape head, capstan and pinch roller.

SPECIFICATION

Power requirement:

DC Input: 2 x 1.5V "AA" (UM-3) batteries (not included) or DC 4.5V±350mA AC adaptor (not included)

Frequency Range

Radio Band: FM 88 - 108MHz
AM 530 - 1710KHz



At Spectra, environmental and social responsibility is a core value of our business. We are dedicated to continuous implementation of responsible initiatives with an aim to conserve and maintain the environment through responsible recycling.

Please visit us at <http://www.spectrainl.com/green.htm> for more information on Spectra's green initiatives or to find a recycler in your area.

E-10

90 DAY LIMITED WARRANTY AND SERVICE VALID IN THE U.S.A. ONLY

SPECTRA MERCHANDISING INTERNATIONAL, INC. warrants this unit to be free from defective materials or factory workmanship for a period of 90 days from the date of original customer purchase and provided the product is utilized within the U.S.A. This warranty is not assignable or transferable. Our obligation under this warranty is the repair or replacement of the defective unit or any part thereof, except batteries, when it is returned to the SPECTRA Service Department, accompanied by proof of the date of original consumer purchase, such as a duplicate copy of a sales receipt.

You must pay all shipping charges required to ship the product to SPECTRA for warranty service. If the product is repaired or replaced under warranty, the return charges will be at SPECTRA's expense. There are no other express warranties other than those stated herein.

This warranty is valid only in accordance with the conditions set forth below:

- The warranty applies to the SPECTRA product only while:
 - It remains in the possession of the original purchaser and proof of purchase is demonstrated.
 - It has not been subjected to accident, misuse, abuse, improper service, usage outside the descriptions and warnings covered within the user manual or non-SPECTRA approved modifications.
 - Claims are made within the warranty period.
- This warranty does not cover damage or equipment failure caused by electrical wiring not in compliance with electrical codes or SPECTRA user manual specifications, or failure to provide reasonable care and necessary maintenance as outlined in the user manual.
- Warranty of all SPECTRA products applies to residential use only and is void when products are used in a nonresidential environment or installed outside the United States.

E-11

This warranty gives you specific legal rights, and you may also have other rights which vary from state to state. TO OBTAIN SERVICE please remove all batteries (if any) and pack the unit carefully and send it freight prepaid to SPECTRA at the address shown below. IF THE UNIT IS RETURNED WITHIN THE WARRANTY PERIOD shown above, please include a proof of purchase (dated cash register receipt) so that we may establish your eligibility for warranty service and repair of the unit without cost. Also include a note with a description explaining how the unit is defective. A customer service representative may need to contact you regarding the status of your repair, so please include your name, address, phone number and email address to expedite the process.

IF THE UNIT IS OUTSIDE THE WARRANTY PERIOD, please include a check for \$15.00 to cover the cost of repair, handling and return postage. All out of warranty returns must be sent prepaid.

It is recommended that you contact SPECTRA first at 1-800-777-5331 or by email at custserv@spectrainl.com for updated information on the unit requiring service. In some cases the model you have may be discontinued, and SPECTRA reserves the right to offer alternative options for repair or replacement.

SPECTRA MERCHANDISING INTERNATIONAL, INC.
4230 North Normandy Avenue,
Chicago, IL 60634, USA.
1-800-777-5331

To register your product, visit the link on the website below to enter your information. <http://www.spectrainl.com/wform.htm>